

MESSRS : All the companies

Product Drawing

CUSTOMER'S PRODUCT NAME:

TDK PRODUCT NAME: DC/DC CONVERTER UNIT ALD-605012Px131



TDK-Lambda Corporation

PREPARED BY	APPROVED BY	AUTHORIZED BY
<i>K.Negoro</i> Nov./1st/2010	<i>H.Masuoka</i> Nov./1st/2010	<i>M.Ueguri</i> Nov./1st/2010



Precautionary Notes Regarding the Use of This Converter

When using this product, give due consideration to the precautionary notes described below and ensure a safe design. Inappropriate use may result in electric shock, injury or fire.

Caution

- This product is designed for the driving LED backlight system.
Do not use it with any other load.
- Store this product under the conditions defined in the specification document.
- Do not store this product in an environment where dust, dirt or corrosive gas(salt,acid,base, etc.) is present.
- This product is designed for use with general electronic equipment.
If it is to be used with medical equipment that directly affects human life or for the control of transportation equipment to which passengers entrust their lives, provide thorough fail-safe measures.
- Avoid using this product under high temperatures or high humidity or in an environment in which dust, dirt or any corrosive gas (salt,acid,base, etc.) is present.
Also,be careful not to allow the formation of dew condensation. It may result in damage or electric shock.
- If the product does not have a built-in protective circuit (circuit breaker, fuse, etc.), it is recommended that a fuse be used at the input stage to prevent the generation of smoke or fire in the event of a malfunction.
Even when the product has a built-in protective circuit (circuit breaker, fuse, etc.), the circuit may not function properly due to inappropriate operating conditions or power-supply capacity.
It is recommended that an appropriate protective circuit (circuit breaker, fuse, etc.) be provided separately from the built-in circuit.
- Use the product only within the specified input voltage, output power, output voltage and operating temperature ranges. Exceeding these values may result in damage, etc.
- Provide a measure for the prevention of surge voltage due to lightning, etc.
Abnormal voltage may result in damage, etc.
- This product is not designed to provide resistance to radiation.
- Ripples could be superimposed on the voltage and the current in the input source connected to the inverter , depending on the impedance in the input source, wiring, etc.
When you select an input source, please check waveforms, etc on the final set.

Handling Precautions

- Do not stack multiple products on top of one another.
- Do not allow the product to come in contact with tools, etc.
- Do not apply excessive stress during installation.
It may cause chipping and cracking,resulting in damage, etc.
- Please do not use the product, when dropping it, since there is a possibility of the parts damage.



1. Product Name

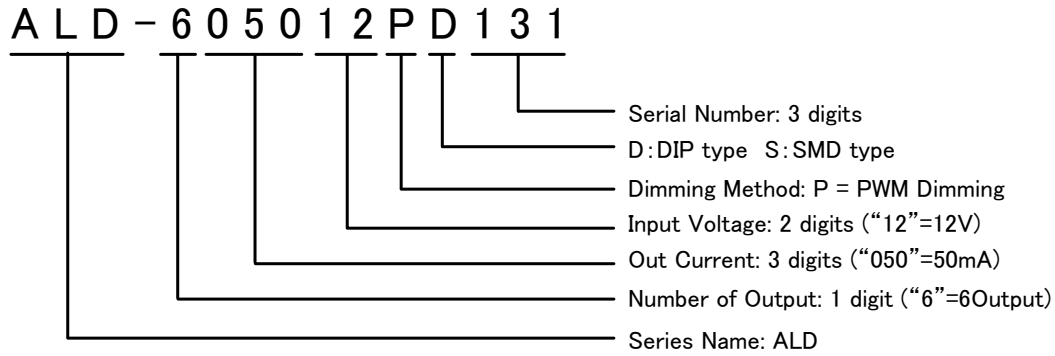

2. Product Summary

- *This product is DC-DC converter that is designed for LED driver.
- *This product has PWM pulse dimming function(Apply external pulse source), Analog dimming(Add an external resistor, external DC voltage) and remote on/off function.
- *This product has alarm function. When load open is happened, alarm output goes high around 5V.



DC-DC Converter Unit ALD-605012Px131: Instruction Manual

3. Terminal Connection

● Please be careful when connecting the input terminal. The converter may be damaged if there is a mistake in the terminal connection or polarity.

Please refer to Table 3-1 and Fig. 3-1 which indicates the input function and connection, and Table 3-2 which indicates the output function

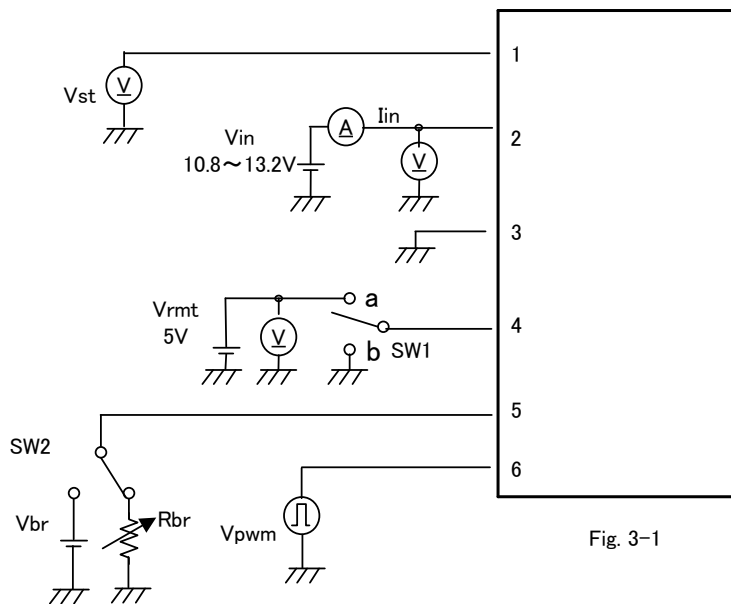

Fig. 3-1

Table 3-1. Input pin

Pin No.	Symbol	Rating	Remark
1	Vst *1	0(V) / 5(V)	Alarm Output
2	Vin	10.8 - 13.2(V)	Input Voltage
3	GND	0(V)	GND
4	Vrmt	OFF : 0 - 0.4(V) ON : 2.5 - Vin(V)	ON/OFF control
5	Rbr*2 Vbr*3	1 - 10(kΩ) 1.6 - 3.8(V)	Analog Dimming
6	Vpwm*4	0(V) : Low(OFF) 3.3(V) : Hi(ON)	PWM Dimming

*1 Normal : 0V / Abnormal : 5V

*2 Rbr=10kΩ:MAX. Brightness , Rbr=1kΩ:MIN. Brightness

*3 Vbr=3.8V:MAX. Brightness , Vbr=1.6V:MIN. Brightness

*4 Vpwm=100%:MAX. Brightness , Vpwm=1%:MIN. Brightness

Table 3-2. Output pin

Pin No.	Symbol	Note
7	-CH1	line1 - cathode side
8	-CH2	line2 - cathode side
9	-CH3	line3 - cathode side
10	Vo	line1~6 - anode side
11	-CH4	line4 - cathode side
12	-CH5	line5 - cathode side
13	-CH6	line6 - cathode side



DC-DC Converter Unit ALD-605012P×131: Instruction Manual

4. Terminal Function

● Vst pin : Alarm output

*Vst terminal is alarm output terminal. Vst outputs around 0V at steady state, around 5V at open LED condition.

If you use the alarm output signal of the DC-DC converter, we recommend high input impedance device like a operation amplifier or a comparator input.

If you use the Vst terminal(Alarm output) for emitting a signal, please take Vst terminal output impedance into consideration.

Fig 4-1.

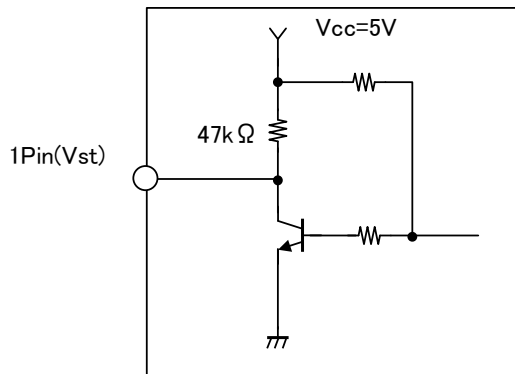

● Vrmt pin : ON/OFF control

If you don't use On/OFF control , please connect Vrmt pin to Vin pin.

	Min.(V)	Max.(V)	Output states
Vrmt	0	0.4	OFF
	Open		OFF
	2.5	Vin	ON

图4-2.

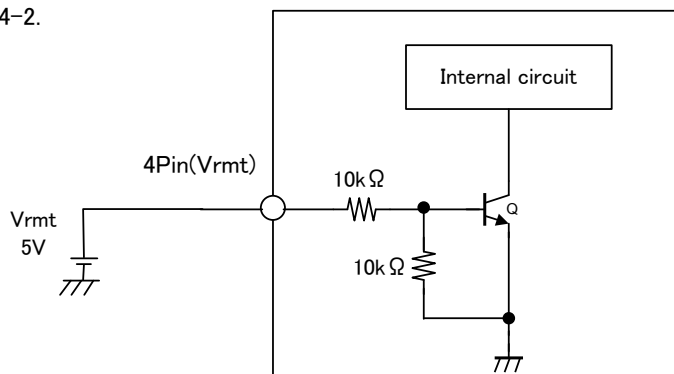



DC-DC Converter Unit ALD-605012Px131: Instruction Manual

● Rbr pin / Vbr pin : Analog dimming

	Io=20mA/string	Io=50mA/string
Use Rbr	1kΩ	10kΩ
Use Vbr	1.6V	3.8V

Rbr is above 0.1W.

Fig 4-3

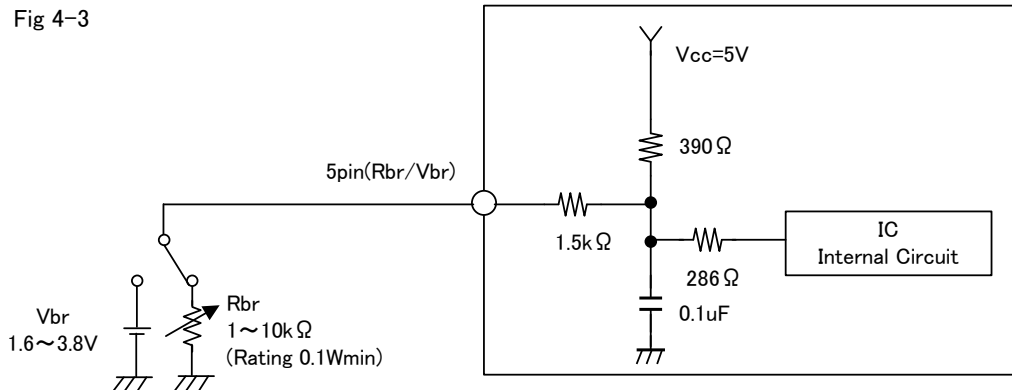

Don't connect more than Rbr=10kΩ, and don't input more than Vbr=3.8V.

Don't use this pin open. If Rbr/Vbr pin open, LED currents are about 60mA/string.

● Vpwm pin : PWM dimming

	Maximum brightness	Minimum brightness
Vpwm	1%	100%

Fig 4-4

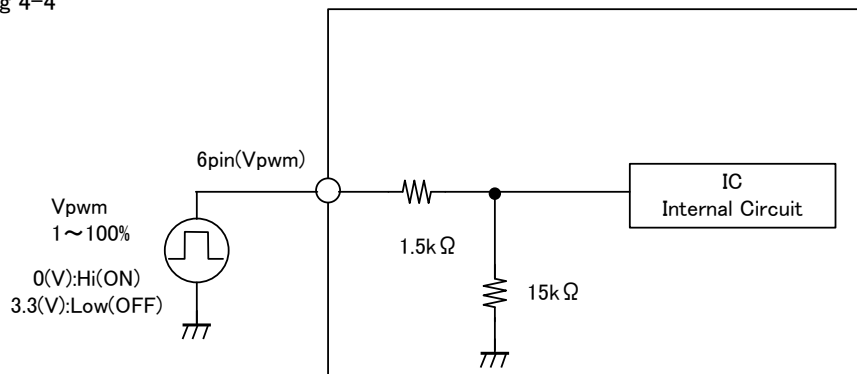



5.Noise Reduction

● Converter noise generation summary

- (1) Ripple noise between input terminals
- (2) Switching noise by main switch
- (3) Induction noise by inductor leakage flux

5-1. Ripple Noise between Input Terminals

The Input terminal of this product is shown the following circuit Figures. 5-1.

Fig 5-1

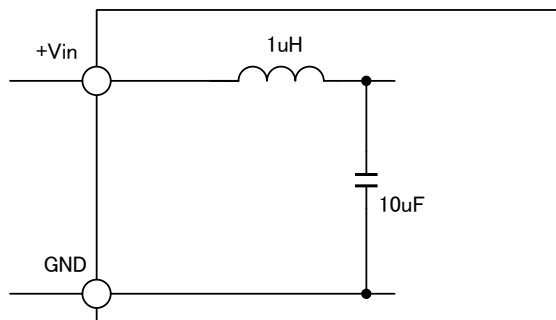

π -type low pass filter is available by attaching an external capacitor to the input terminal. This filter is effective against ripple voltage and current at the input terminal. And this filter is not susceptible to ESR and capacitance because an inductor is on the input line.

There is no built-in fuse in this converter.
Please select an external fuse on Customers condition.

Fig 5-2

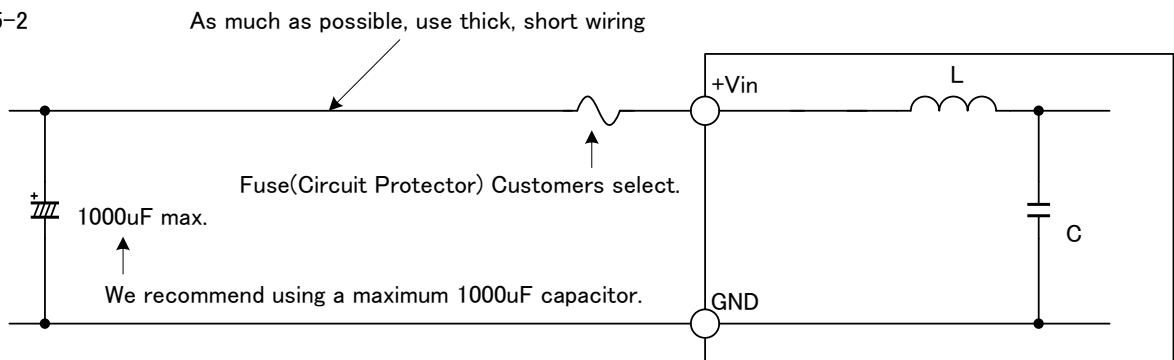

*When a fuse breaks, the Alarm Signal does not operate.



DC-DC Converter Unit ALD-605012Px131: Instruction Manual

5-2. Switching Noise by Main Switch

This product adopts the boost up chopper topology.
The switching frequency is about 450kHz.

Noise may appear at basic frequency and odd number times of frequency.
Please confirm that the final set is not affected by this noise.

If the conduction noise level becomes a problem, please insert the low-pass filter, the normal mode filter, and the common mode filter of the multistage configuration in the input side according to the kind of the noise, and please use the clamping filter for the I/O cable to decrease the line noise in the power supply, as shown in Figure 5-3.

If the radiation noise level becomes a problem, please shield or separate the distance from electrical loop with main MOSFET, diode, and capacitor.

Fig 5-3

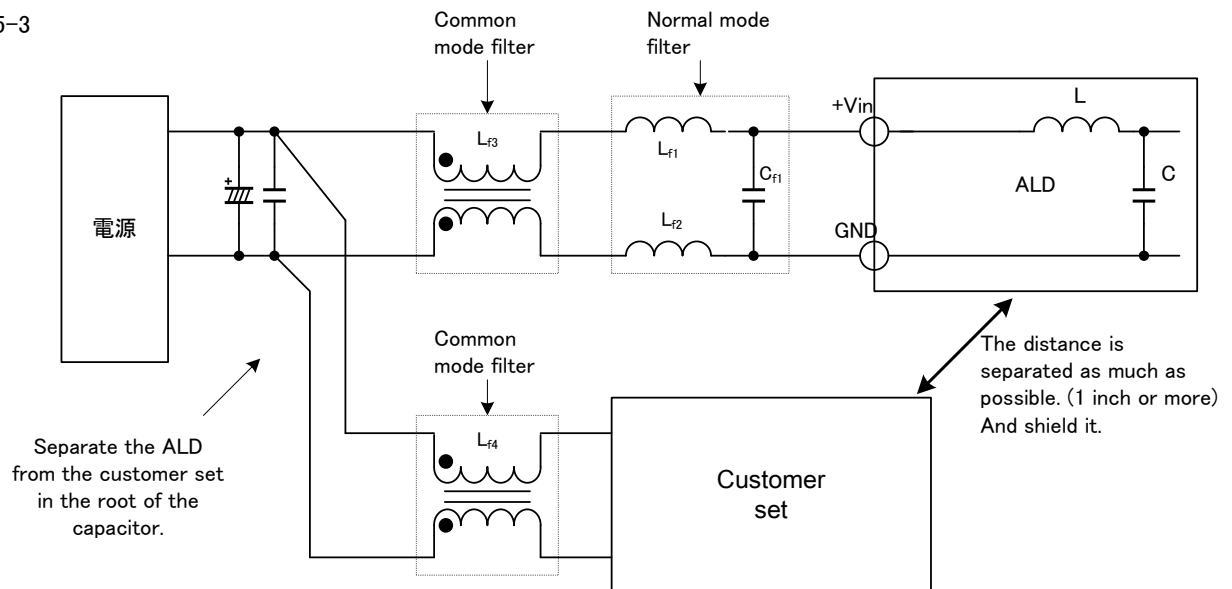

Please measure the noise as follows,

1. Remove the clip from the probe head. In order to minimize the loop of signal- GND. However, there is a possibility that the noise gets on according to the measuring method.

2. Measure it with the following cables,

JEITA(Japan Electronics and Information Technology Industries Association), RC9141, 7.13 Fig.C

<http://www.jeita.or.jp/english/>

We use the measuring method of 2.

5-3. Induction Noise by Inductor Leakage Flux

In this product, the choke inductor is the component that generates leakage flux.

The inductor may affect the high impedance line of near field because of the huge leakage flux.

Please be careful do not place signal path near field of inductor.

And if you shield leakage flux by high permeability material at close range of inductor top, eddy current losses by leakage flux occurs. As a result, it reduces circuit efficiency and causes unexpected heat up.

Please be sure to keep enough space between shield materials and the inductor.



6 Protection Function

*This product is equipped with the following protection circuits:

- (1) Open LED protection circuit (Alarm output)
- (2) Over Voltage protection circuit(Alarm output)
- (3) Over Current protection

6-1.Open LED protection circuit

If one of the LED strings is open, the opened string stop working ,and the other strings work normally.
The alarm output is Hi(around 5V) when any string is in an open condition.

6-2.Over Voltage protection circuit

When over voltage protection circuit operates, the converter continues operation minimum duty cycle.
In this time, output voltage is about 15V.
The alarm output is Hi(around 5V).

6-3.Over Current protection circuit.

When over current protection circuit operates, output current decrease.
If over current goes off, the unit operates normally.



7. Alarm Output Function

*The unit has an alarm output function. The Alarm output is 0~1V at normal condition and around 5V at abnormal condition. Please confirm the following precautions :

7-1. Recommended Power On/Off Sequence

*Turn On Sequence

- 1) apply input voltage
- 2) apply V_{pwm} and V_{br} voltage (recommend low impedance output like operation amplifier output etc.)
- 3) apply remote on/off voltage (recommend High signal at open collector with pull-up or logic output)
*Please provide mask for the alarm signal at turn on when you control external product by monitoring alarm output. (Please refer to Fig.7-1:recommended sequence)

*Turn Off Sequence

- 1) turn off remote on/off voltage(recommend Low signal at open collector or logic output)
- 2) turn off V_{pwm} and V_{br} voltage (recommend low impedance output like operation amplifier output etc.)
- 3) turn off input voltage
*Please provide mask for the alarm signal at turn off when you control external product by monitoring alarm output. (Please refer to Fig.7-1:recommended sequence)

7-2. Turn on input voltage and remote on/off voltage simultaneously

*Turn On Sequence

When input voltage is lower than working voltage of IC, the alarm signal may activate.

When the rise time of input voltage is long, the alarm signal may activate.

*Please provide mask for the alarm signal at turn on when you control external product by monitoring alarm output. (Please refer to Fig.7-1:recommended sequence)

*Turn Off Sequence

When input voltage is lower than working voltage of IC, alarm signal may activate.

When the fall time of input voltage is long, the alarm signal may activate.

*Please provide mask for the alarm signal at turn off when you control external product by monitoring alarm output. (Please refer to Fig.7-1:recommended sequence)



Fig7-1.Recommended Power On/Off Sequence

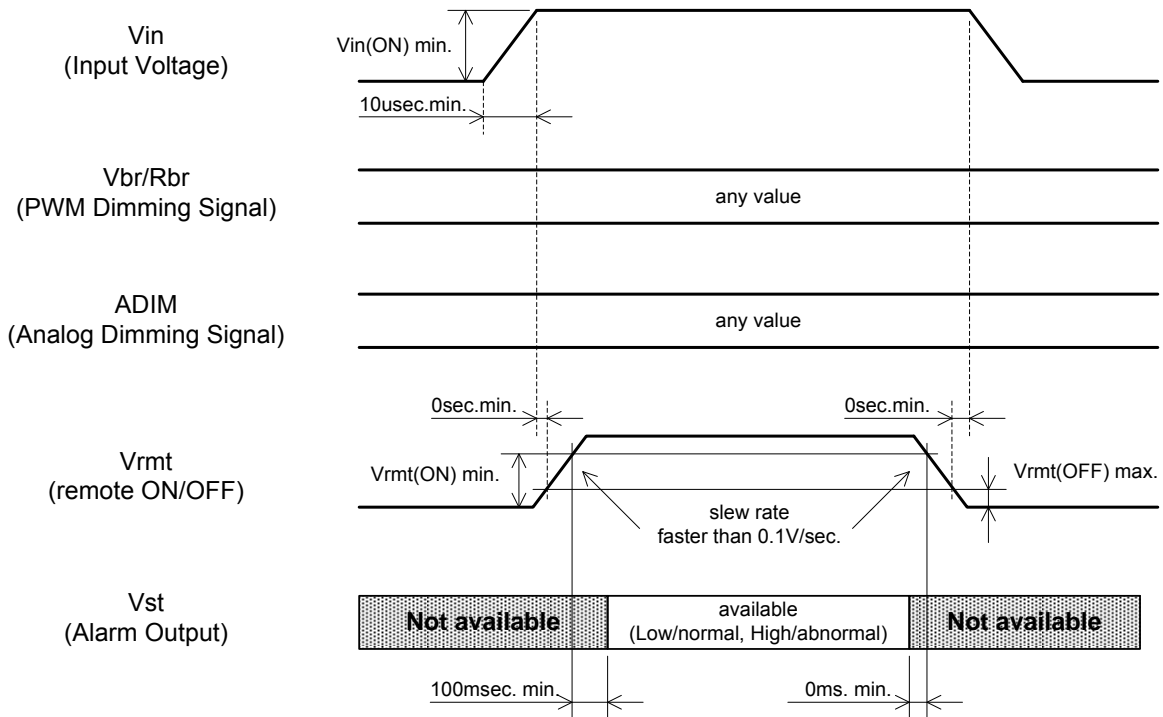

- $V_{in(ON) \min.}$: minimum of recommended working input voltage
- $V_{rmt(ON) \min.}$: minimum Vrmt on voltage
- $V_{rmt(OFF) \max.}$: maximum Vrmt off voltage



8 Soldering Temperature

【DIP Type】

Solder DIP 260°Cmax 10sec max.
Solder IRON 380°Cmax 3sec max. (1time/PIN)

【SMD Type】

Lead free solder / high temperature reflow process conditions are shown in below figure.
The number of reflow is 1 time.

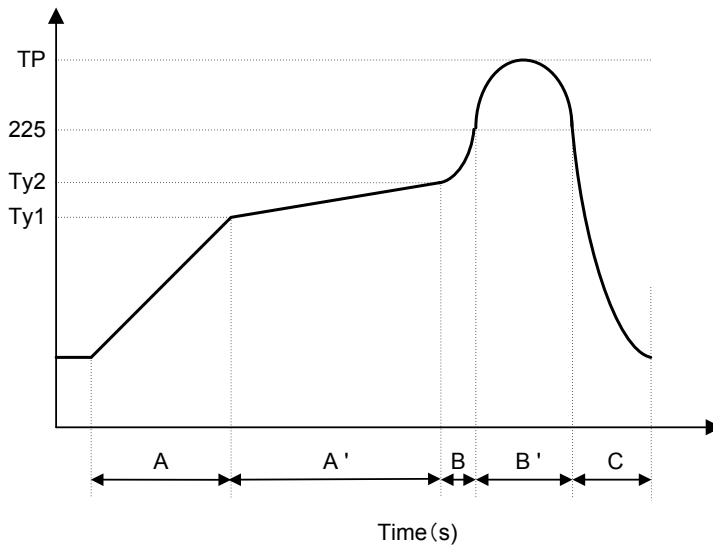

A	1.0~3.0°C/sec
A'	Ty1: 150±10°C Ty2: 170±10°C Ty1~Ty2: 20~100sec
B	1.0~4.0°C/sec
B'	TP: MAX 245°C 225°C MIN: 20~40sec
C	-1.0~-5.0°C/sec



9. Other Caution Instructions

Please avoid to control dimming by Vrmt terminal. When you want to use dimming, please use Vpwm or Rbr(Vbr) terminal. When you handle the unit, please be careful to keep unit's components from coming in contact with anything. This unit does not allow hot plugging. When the unit is operating do not plug in or plug out the connector.

10. Flicker Considerations

In PWM or Analog Dimming operation, please confirm the LCD panel operation before use. Flickering may occur due to ripple noise is on Dimming pin(Vpwm / Vbr / Rbr).

11. Dimming Noise Considerations

In PWM Dimming operation, please confirm whether to hear the noise before use. Noise may occur according to the state of the substrate installation when the PWM Dimming pin(Vpwm) is used.

12. Mounting Instruction

Please wire GND pattern under unit as far as possible .
If signal ptttern is wired under unit,it may occur false operation.



13. Reference diagram of connecting LED

Fig. 13-1

• single series

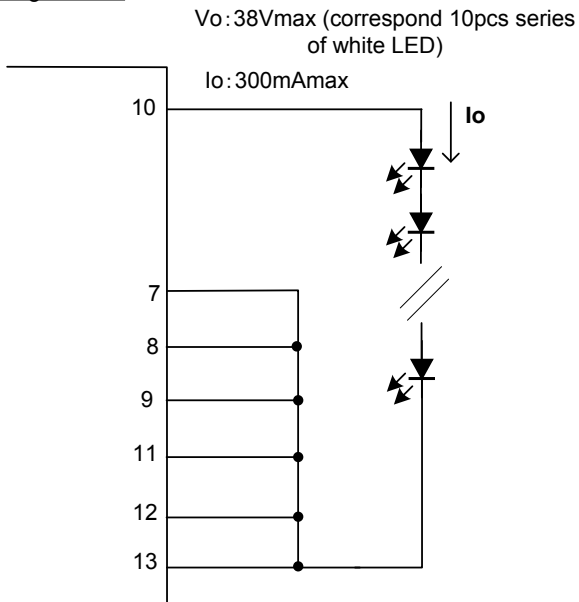

Fig. 13-2

• 2 parallel

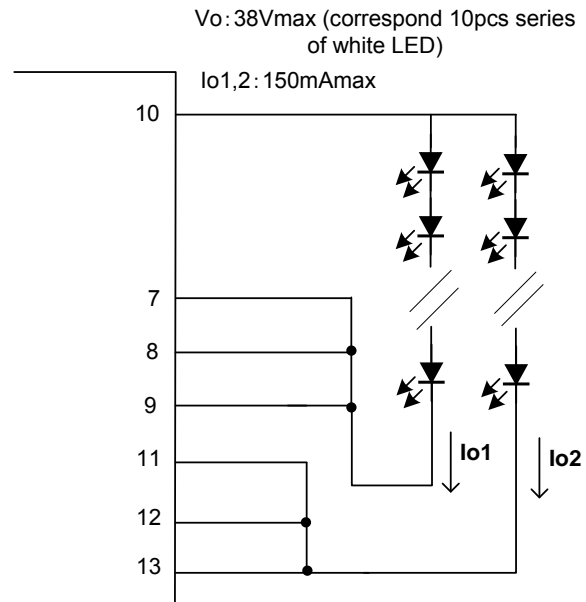

Fig. 13-3

• 3 parallel

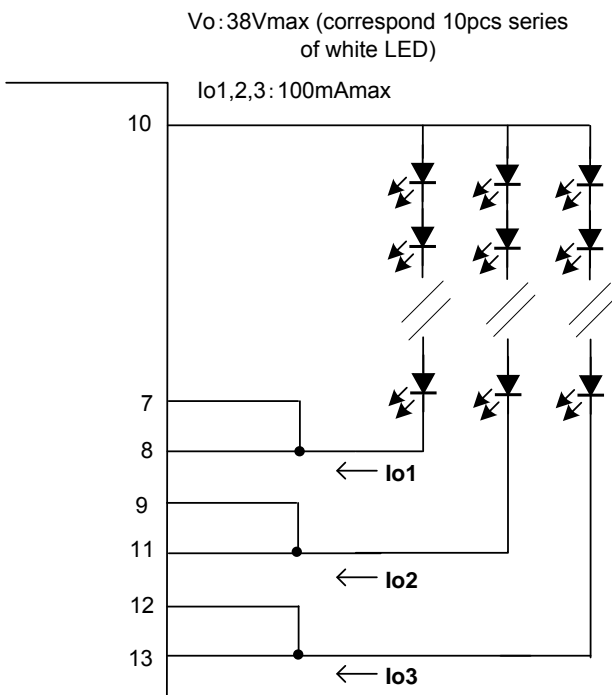
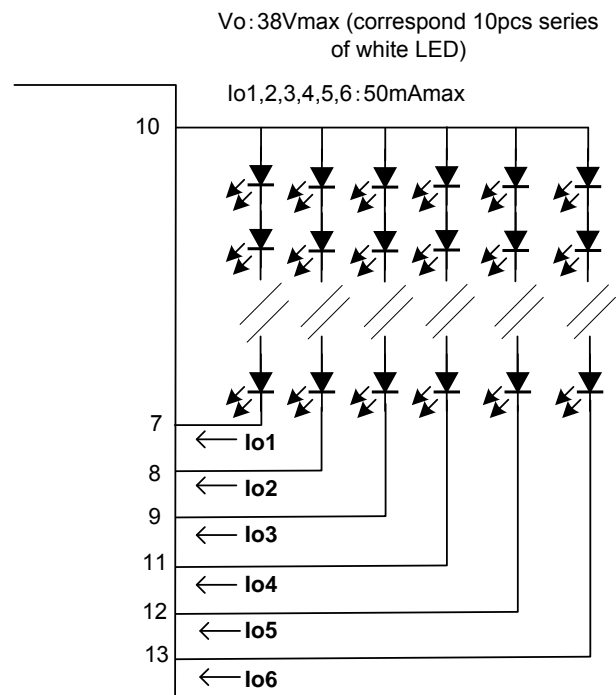

Fig. 13-4

• 6 parallel





<Reference date>

14 Electrical date

These date(page.15~17) are measured in following measurement circuit (single series).

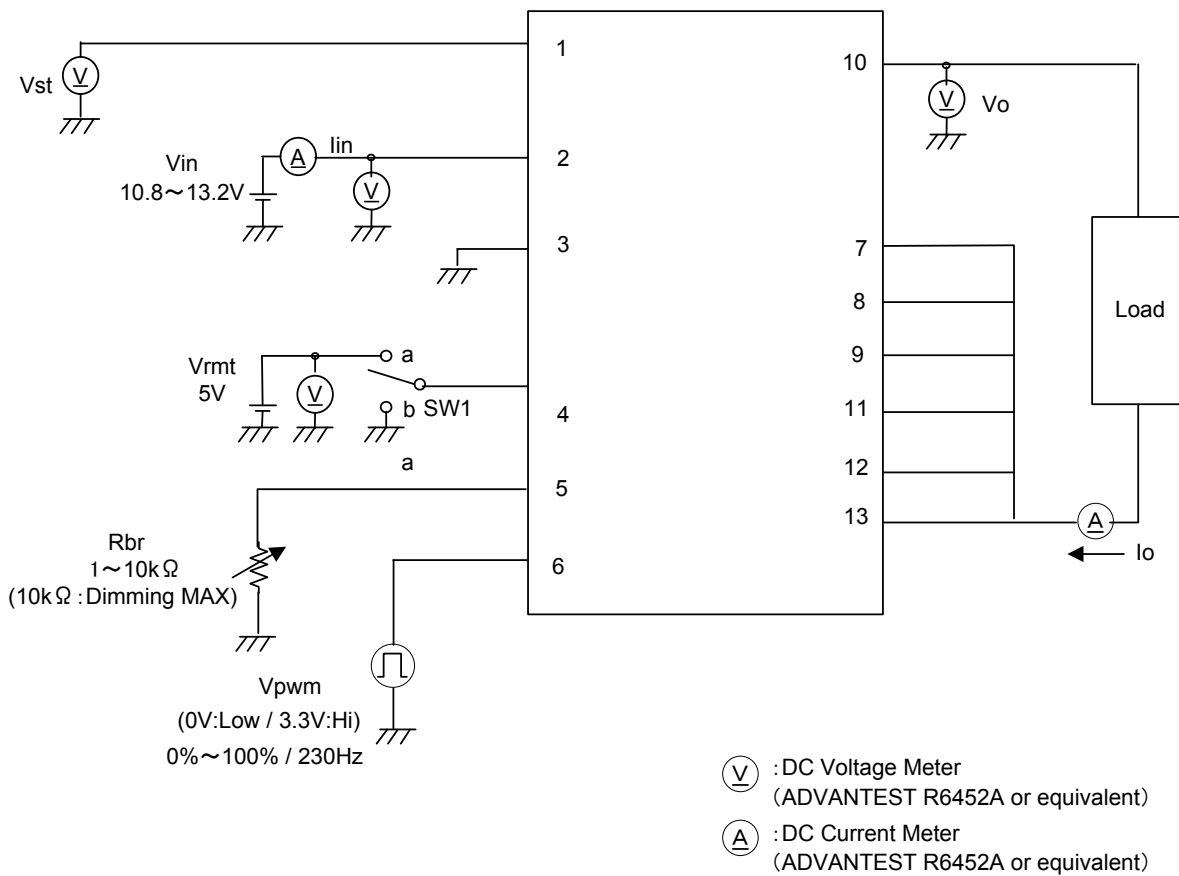



DC-DC Converter Unit ALD-605012Px131: Instruction Manual

(1) Load Disturbance

Ta : 25°C
Vin : 12V
Vrmt : 5V
Rbr : 1-10kΩ
Vpwm : 100%

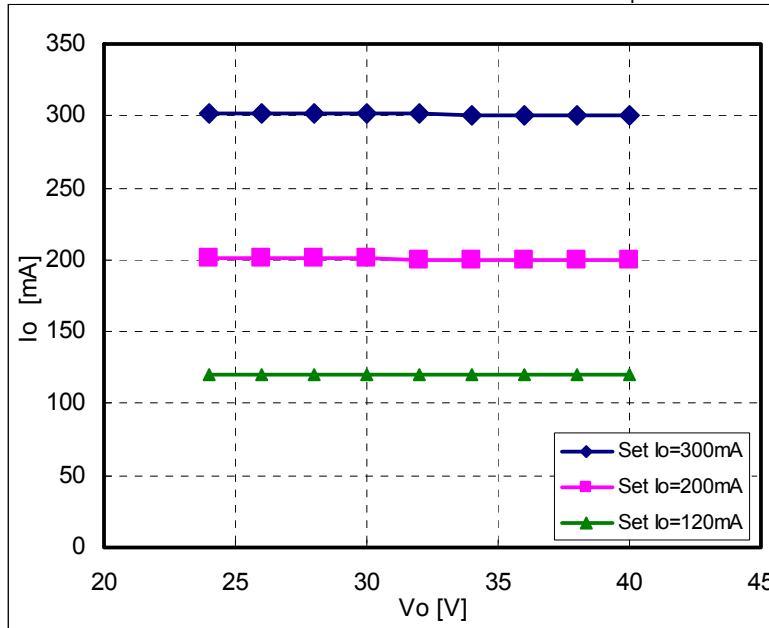

(2) Input Disturbance

Ta : 25°C
Vin : 10.8-13.2V
Vrmt : 5V
Rbr : 10kΩ
Vpwm : 100%

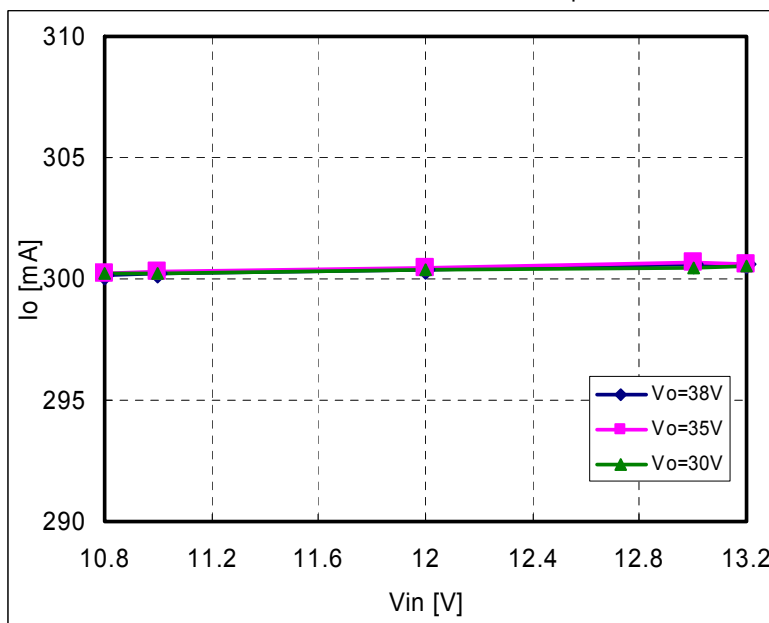



DC-DC Converter Unit ALD-605012Px131: Instruction Manual

(3) PWM Dimming Characteristic

Ta : 25°C
Vin : 12V
Vrmt : 5V
Rbr : 1-10kΩ
Vpwm : 1-100%

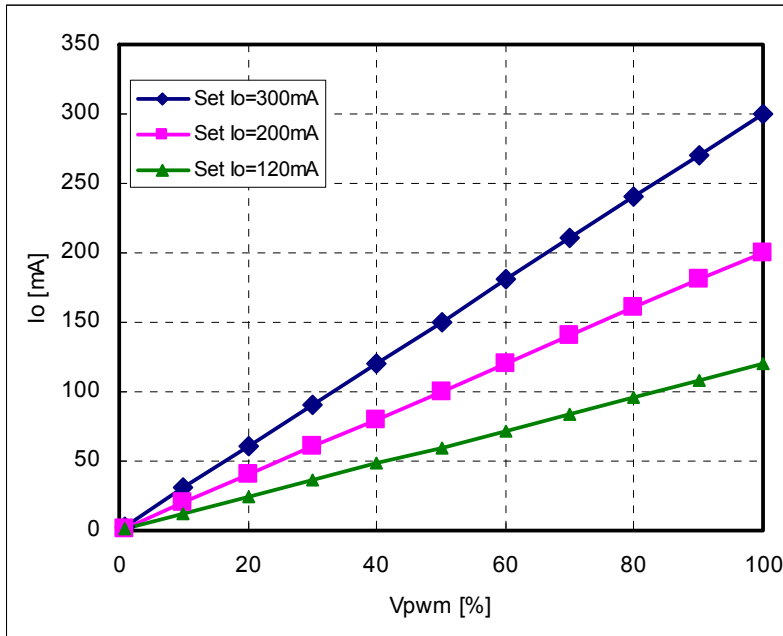

(4) ADIM Dimming Characteristic

Ta : 25°C
Vin : 12V
Vrmt : 5V
Rbr : 1-10kΩ
Vpwm : 100%

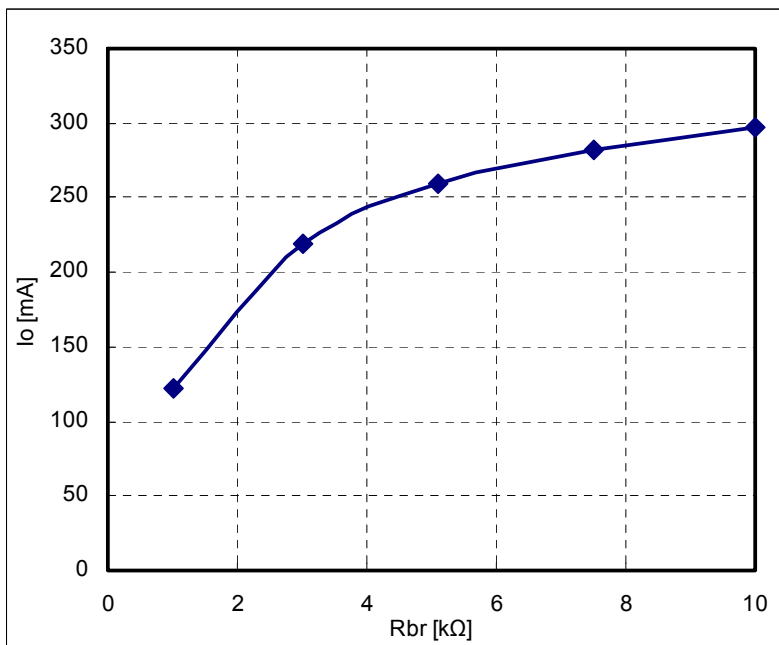



DC-DC Converter Unit ALD-605012Px131: Instruction Manual

(6) Temperature Derating Curve

Temperature rise is different depending on product setting.
Please confirm in follow the procedure

- ① Detach the case from this product ,then setting on your board.
- ② Fit on thermocouple,and attach the case.
- ② Keep aging to saturation temperature on your worst-case condition(maximum output current ,and Operating Temperature).
- ③ Measure following point'A,B'.
Please maintain a surface temperature of 'A' under 120°C.
Please maintain a surface temperature of 'B' under 104°C.

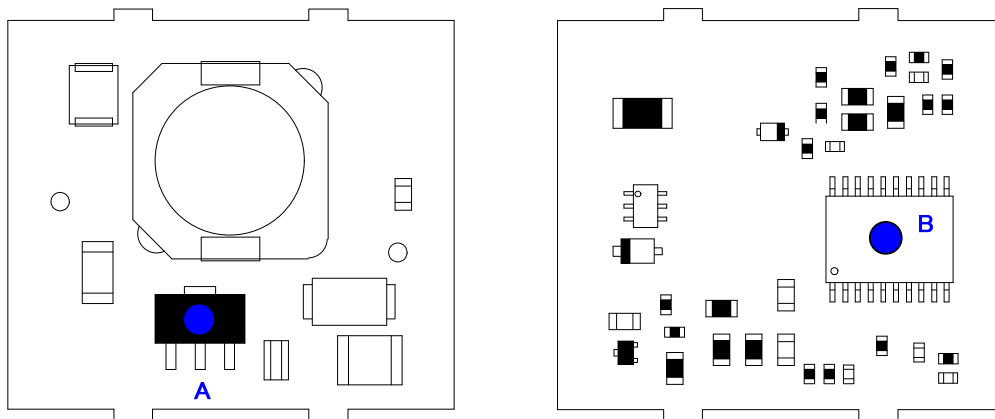

The following is derating curve of output current on our evaluation board.
 I_o =Total I_o current of CH1~6.

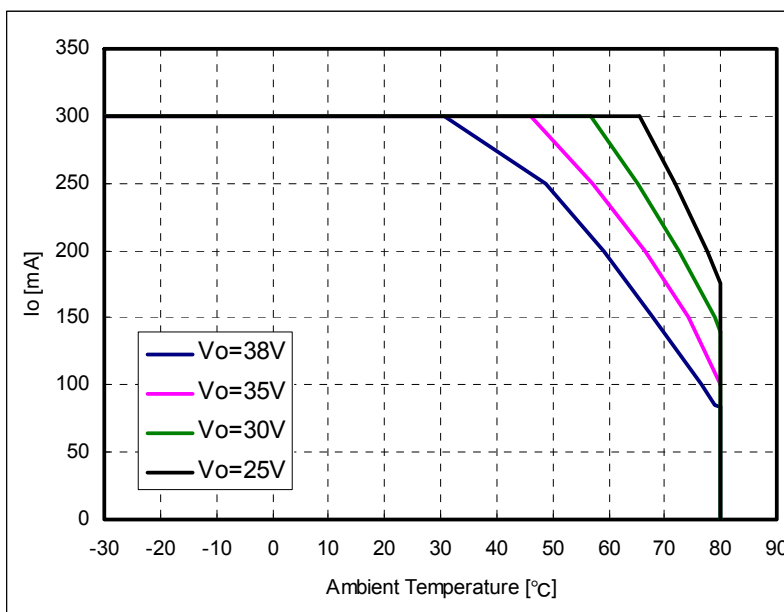

*Attention : In the case of parallel connection, temperature rise of IC(point 'B') is higher if each string has varied voltage (total of forward voltage).