

MESSRS :

---

PRODUCT DRAWING

---

CUSTOMER'S PRODUCT NAME:

---

TDK PRODUCT NAME: DC/AC INVERTER UNIT  
CXA-P1612-VJL

---



TDK Corporation

Corporate Headquarters  
13-1, Nihonbashi 1-chome, Chuo-ku,  
Tokyo 103, JAPAN  
Telephone : 03-3278-5111  
2-15-7, Higashi-Ohwada, Ichikawa-shi,  
Chiba, 272-8558 JAPAN  
Telephone : 047-378-9671  
Fax : 047-378-9673

PREPARED BY	APPROVED BY	AUTHORIZED BY
<i>Sep. 11. 2005 H. Mitsumoto</i>	<i>Sep. 11. 2005 E. Takahashi</i>	<i>Sep. 11. 2005 K. Hanabusa</i>

DWG.No.	CTR-0751-B
---------	------------

## Precautionary Notes Regarding the Use of This Inverter

When using this product, give due consideration to the precautionary notes described below and ensure a safe design. Inappropriate use may result in electric shock, injury or fire.



### Warning



This product is subject to high voltage. Do not touch it while the power is on.  
Failing to do so may result in electric shock.



### Caution

This product is designed for the lighting of a Cold Cathode Fluorescent Lamp.  
Do not use it with any other load.  
Store this product under the conditions defined in the specification document.  
Do not store this product in an environment where dust, dirt or corrosive gas (salt, acid, base, etc.) is present.  
This product is subject to high voltage. If there is a possibility that the user may touch the product, provide a proper indication in order to draw the user's attention.  
This product is designed for use with general electronic equipment.  
If it is to be used with medical equipment that directly affects human life or for the control of transportation equipment to which passengers entrust their lives, provide thorough fail-safe measures.  
Avoid using this product under high temperatures or high humidity or in an environment in which dust, dirt or any corrosive gas (salt, acid, base, etc.) is present.  
Also, be careful not to allow the formation of dew condensation. It may result in damage or electric shock.  
If the product does not have a built-in protective circuit (circuit breaker, fuse, etc.), it is recommended that a fuse be used at the input stage to prevent the generation of smoke or fire in the event of a malfunction.  
Even when the product has a built-in protective circuit (circuit breaker, fuse, etc.), the circuit may not function properly due to inappropriate operating conditions or power-supply capacity. It is recommended that an appropriate protective circuit (circuit breaker, fuse, etc.) be provided separately from the built-in circuit.  
Use the product only within the specified input voltage, output power, output voltage and operating temperature ranges. Exceeding these values may result in damage, etc.  
Provide a measure for the prevention of surge voltage due to lightning, etc.  
Abnormal voltage may result in damage, etc.  
To prevent problems arising from short-circuiting of the high-voltage section, provide appropriate measures to prevent the entry of foreign substances following installation.  
This product is not designed to provide resistance to radiation.  
Ripples could be superimposed on the voltage and the current in the input source connected to the inverter, depending on the impedance in the input source, wiring, etc.  
When you select an input source, please check waveforms, etc on the final set.

### Handling Precautions

This product uses thin wires. Observe the following precautions and handle it with care so as not to cause wire breakage. Broken wire may result in damage, etc.

- Do not stack multiple products on top of one another.
- Do not allow the product to come in contact with tools, etc.

Do not apply excessive stress during installation.  
It may cause chipping and cracking, resulting in damage, etc.  
Provide a clearance of 2 mm or more between the high-voltage section of this product and the frame body on which the product is installed and also the conductor section (pattern, pad, etc.).  
Please do not use the product, when dropping it, since there is a possibility of the parts damage.  
Please confirm abnormality is not found in the product enough when using it by any chance.

	PRODUCT NAME or MODEL, TITLE		
	DC-AC INVERTER UNIT CXA-P1612-VJL		
TDK CORPORATION	NAME OF DRAWING	DRAWING No.	PAGE
	PRODUCT DRAWING	CTR-0751-B	1

<The specifications may be changed without any notice.>

- The specifications may be changed without any notice.
- When placing orders, please confirm "Specifications" or "Product Drawing" through TDK sales or distributors.

Features

- This inverter is for two lamps. It has Dimming function and Remote function.
  - The high-voltage area (terminals and patterns) is coated with silicone so as to avoid the defects caused by dust.
  - This product is conformity to RoHS directive.\*
- \* : Conformity to RoHS Directive: This means that, in conformity with EU Directive 2002/95/EC, lead, cadmium, hexavalent chromium, and specific bromine-based flame retardants, PBB and PBDE, have not been used, except for exempted applications.

[1] Outline

1-1. Outline

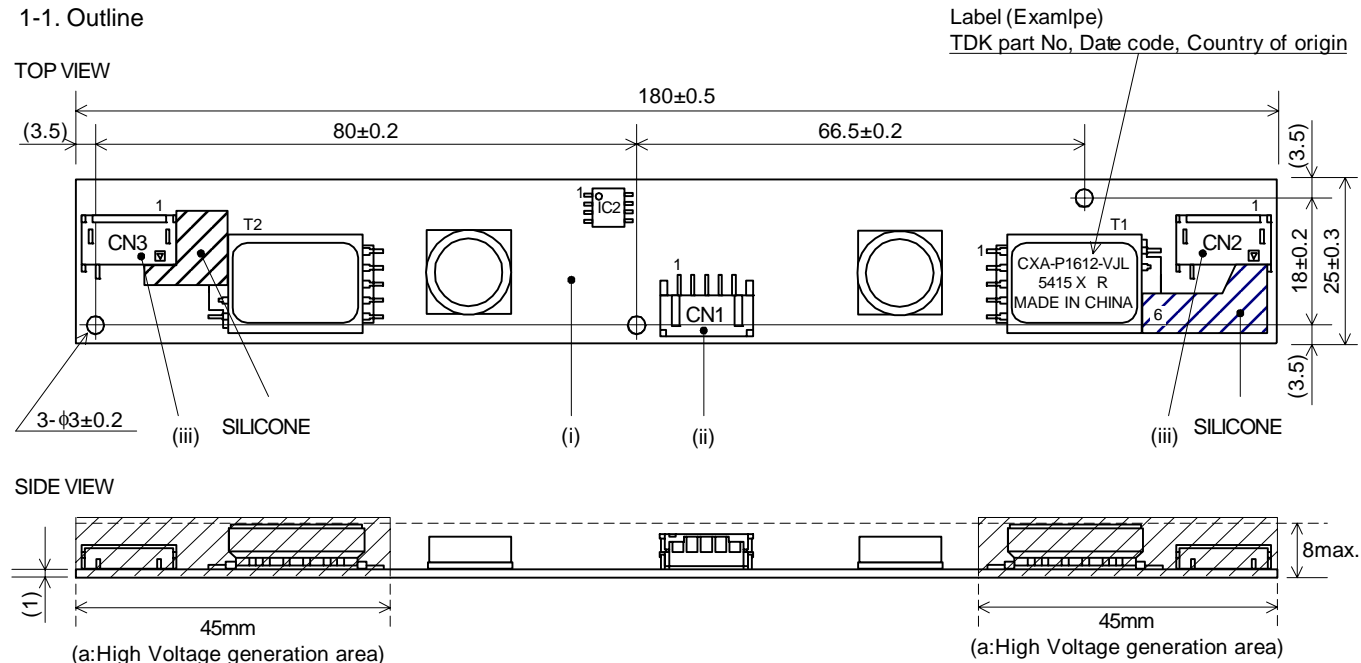

\*Please secure the air clearance of 2mm or more from the high voltage generation area up and down and right and left. Please refer to Note1-3. for details.

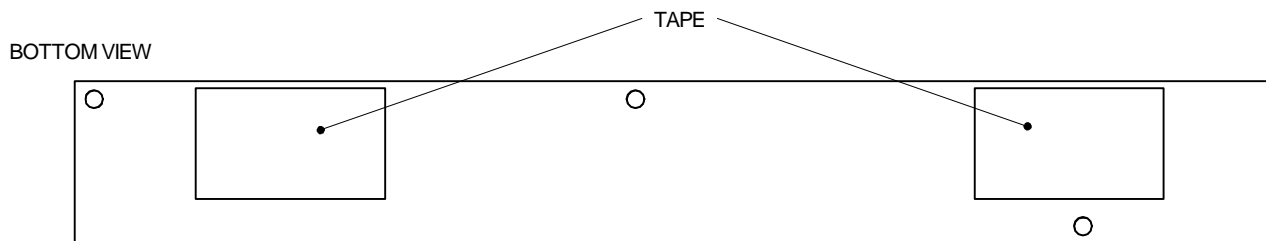

Unit:mm

Weight:29.6g.typ.

No.	Part Description	Material	QU	REMARK	MATES WITH
(i)	PCB	Composite (CEM-3)	1	UL94V-0 t=1.0	-
(ii)	Input Connector CN1	S5B-PH-SM4-TB(LF)(SN)	1	JST	PHR-5
(iii)	Output Connector CN2,CN3	SM02(8.0)B-BHS-1-TB(LF)(SN)	2	JST	BHR-03VS-1

PRODUCT NAME or MODEL,TITLE			
DC-AC INVERTER UNIT CXA-P1612-VJL			
TDK CORPORATION	NAME OF DRAWING	DRAWING No.	PAGE
	PRODUCT DRAWING	CTR-0751-B	2

<The specifications may be changed without any notice.>

Example of naming product C X A - P 1 6 1 2 - V J L

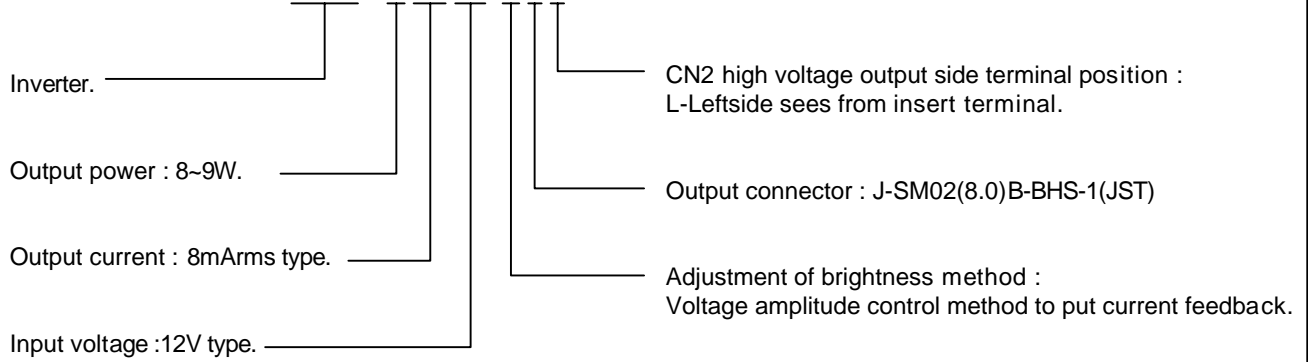

1-2. Connector Configuration

Input side CN1

Pin No.	Symbols	Ratings	Notes
CN1-1	Vin	10.8-13.2V	
CN1-2	GND	0V	
CN1-3	Vbr	0-2.5V	
CN1-4	N.C.	0-3V	
CN1-5	Vrmt	0V/2.5V-Vin	0~0.4V:OFF 2.5~Vin:ON

Output side CN2

Pin No.	Symbols	Ratings
CN2-1	VHIGH1	560Vrms 8mArms
CN2-2	N.C.	-
CN2-3	VLOW1	(0.6V)

Output side CN3

Pin No.	Symbols	Ratings
CN3-1	VHIGH2	560Vrms 8mArms
CN3-2	N.C.	-
CN3-3	VLOW2	(0.6V)

Note1-1. Marking of TDK part No, Date code, Country of origin.

1) TDK part No., Date code, Country of origin, is marked on the transformer.

2) Date code example. (ex. APR. 15. 2005)

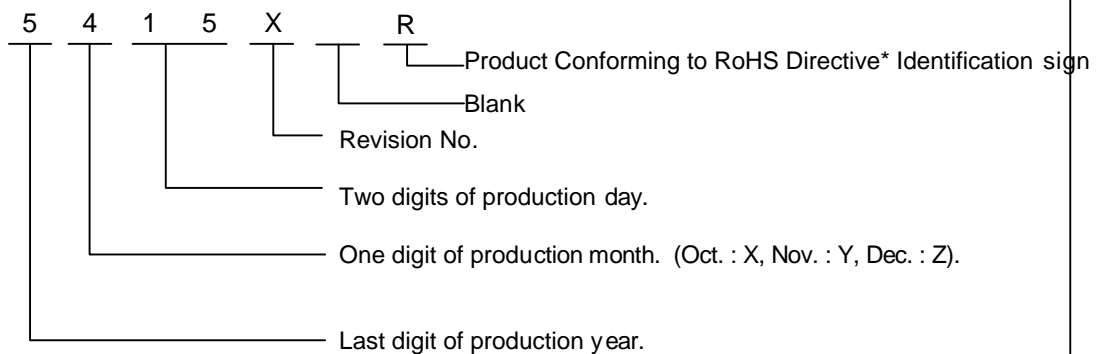

3) Country of origin code example. (ex. MADE IN JAPAN. MADE IN CHINA).

\* : Conformity to RoHS Directive: This means that, in conformity with EU Directive 2002/95/EC, lead, cadmium, hexavalent chromium, and specific bromine-based flame retardants, PBB and PBDE, have not been used, except for exempted applications.

	PRODUCT NAME or MODEL, TITLE		
	DC-AC INVERTER UNIT CXA-P1612-VJL		
TDK CORPORATION	NAME OF DRAWING	DRAWING No.	PAGE
	PRODUCT DRAWING	CTR-0751-B	3

<The specifications may be changed without any notice.>

Note1-2. For circuit connection, please refer to test circuit diagram [4].

Note1-3. Please use minimum of 2mm clearance (all directions) between inverter high voltage area and any conductors. Please refer to mechanical drawing for marking of high voltage area.

Note1-4. Open voltage (strike voltage) is measured across the transformer secondary winding at no load as the reading at the output connector would be less than the actual value.

Note1-5. If the start up voltage falls below Cold Cathode Tube strike voltage, the CCFL will not light up easily especially at lower ambient temperature. Please review mounting instruction to avoid any abnormal operation due to coupling/leakage capacitance of inverter high voltage area to any surrounding conductor.

Note1-6. Please check your lamp characteristic for minimum operational current and set the limit point in your design to avoid flickering and/or abnormal operation.

Note1-7. For proper operation of circuit protection (fuse or IC), please use minimum of 3A capacity for input power supply.

[2] Absolute maximum ratings

Item	Symbol	Specification	Unit	Notes
Input Voltage	Vin	0~14.4	V	
	Vrmt			
	Vbr	0~3		
Output Power	Po	5	W	5W/One Lamp (Total:10W)
Operating Temp. range	Ta	0~60	°C	
Storage Temp. range	Ts	-30~85	°C	
Humidity range	RH	95	%RH	A maximum wet ball temperature is 38°C No dew.

PRODUCT NAME or MODEL, TITLE			
DC-AC INVERTER UNIT CXA-P1612-VJL			
TDK CORPORATION	NAME OF DRAWING	DRAWING No.	PAGE
	PRODUCT DRAWING	CTR-0751-B	4

<The specifications may be changed without any notice.>

[3] Electrical specifications

Item	Symbol	Conditions					Specifications			Unit
		Vin [V]	Vrmt(V)	Vbr(V)	Ta(°C)	RL(kΩ)	MIN.	TYP.	MAX.	
Output Current (Brightness max.)	Iout1/ Iout2	10.8±0.05	5±0.05	0	0-60	70±2	7.2	8.0	8.8	mA rms
		12±0.05	5±0.05	0	0-60	70±2	7.2	8.0	8.8	
		13.2±0.05	5±0.05	0	0-60	70±2	7.2	8.0	8.8	
Output Current (Brightness min.)	Iout1/ Iout2	12±0.05	5±0.05	2±0.05	0-60	70±2	3.5	4.0	4.5	
Input Current	Iin	12±0.05	5±0.05	0	0-60	70±2	-	1.0	1.5	A
Frequency	F1	12±0.05	5±0.05	0	0-60	70±2	50	55	60	kHz
Frequency (Duty)	F2	12±0.05	5±0.05	2±0.05	0-60	70±2	225	270	335	Hz
Open Circuit Voltage	Vopen	10.8±0.05	5±0.05	0	0-60	∞	1.5	1.6	-	kV rms

[4] Test circuit

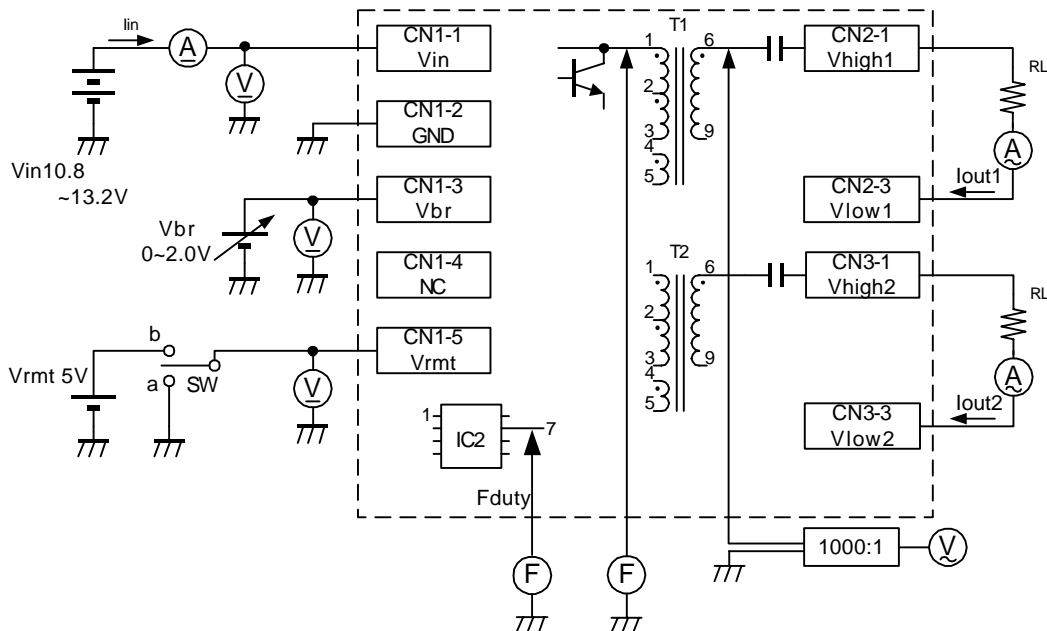

\*For the number of the component's position, please refer to Outline diagram [1].

Note4-1. SW(ON/OFF) Operation is as following;

SW		Operation of unit
a	0-0.8V	Non operation
b	2.5-14.4V	Operation

Note4-2. Test Equipments

- (V) Digital Multiple Meter(ADVANTESTR6451A or equivalent)
- (A) DC Current Meter(ADVANTEST R6451A or equivalent)
- (F) Frequency Countor(ADVANTEST R6452A or equivalent)
- (V) True RMS Meter(KEITHLEY 2001 or equivalent.)
- (A) High Frequency Current Meetr(KEITHLEY 2001 or equivalent)
- 1000:1 High Voltage Probe(Tektronix P3000 or equivalent)

PRODUCT NAME or MODEL, TITLE			
DC-AC INVERTER UNIT CXA-P1612-VJL			
TDK CORPORATION	NAME OF DRAWING	DRAWING No.	PAGE
	PRODUCT DRAWING	CTR-0751-B	5

<The specifications may be changed without any notice.>

Connection diagram of LCD module (Reference)

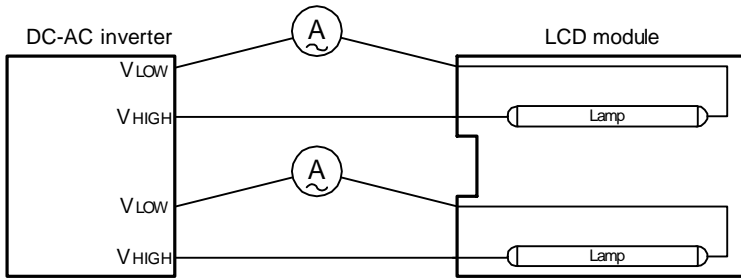

Remote terminal circuit (Reference)

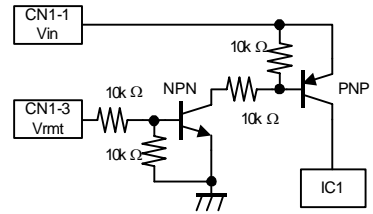

Dimming characteristic (Reference)

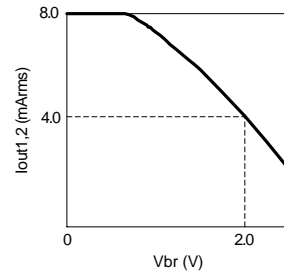

[5] Reliability test

Following test items are assured.

Item	Condition	Judgement
Low Temp.Non operational	-30°C 500h	Electrical and apperance should be in the spec.
Low Temp.operational	0°C 500h Load cond.:TYP	
High Temp.Non operational	85°C 500h	
High Temp.operational	60°C 500h Load cond.:TYP	
Heat shock	-30°C↔85°C 30min.Each 100 Cycles	
Humidity (Non operational)	60°C 90~95%RH 500h	
Vibration	10~57Hz Amplitude0.75mm 58~500Hz 1G Sweep:11min 60min each axis X,Y,Z	
Shock	100G 11ms Harf-sine pulse 1 time each axis ±X,Y,Z	

PRODUCT NAME or MODEL,TITLE			
DC-AC INVERTER UNIT CXA-P1612-VJL			
TDK CORPORATION	NAME OF DRAWING	DRAWING No.	PAGE
	PRODUCT DRAWING	CTR-0751-B	6

<The specifications may be changed without any notice.>

[6] Packing and Marking

A shipping box is packaged to avoid from damage. Following items are printed on the box.

- 6-1. TDK part No. CXA-P1612-VJL
- 6-2. Manufacture TDK
- 6-3. Customer part No.
- 6-4. QTY.
- 6-5. Inspection No.
- 6-6. Country of origin

Packing style as under Fig. (50 going in with a standard.)

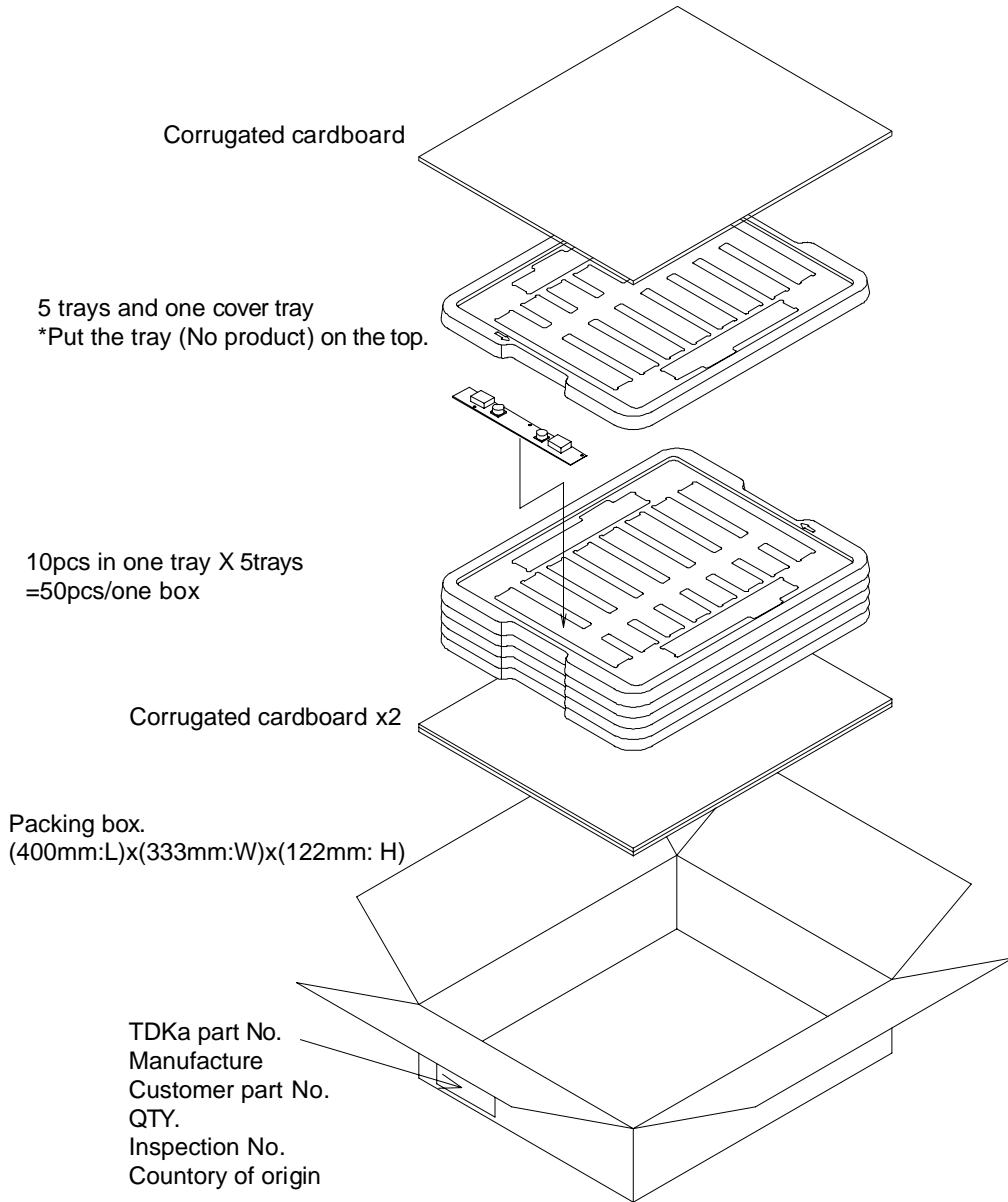

[7] Others

- 7-1. Test cond.  
A normal test condition :Temperature (20±15°C), Humidity (65±20%RH).
- 7-2. Std warantry  
One year after shipment. This covers any defects in material or workmanship.  
Defective units will be replaces at no charge.
- 7-3. Others  
TDK and customer are to discuss changes, problems, and modifications and etc, when needed.

	PRODUCT NAME or MODEL, TITLE		
	DC-AC INVERTER UNIT CXA-P1612-VJL		
TDK CORPORATION	NAME OF DRAWING	DRAWING No.	PAGE
	PRODUCT DRAWING	CTR-0751-B	7

<The specifications may be changed without any notice.>